

Toolholders for inserts LCMF

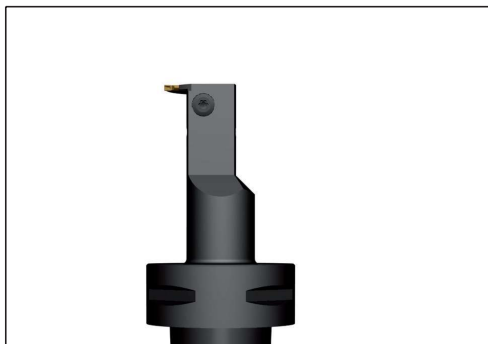

• For inserts programme, see page(s) 632

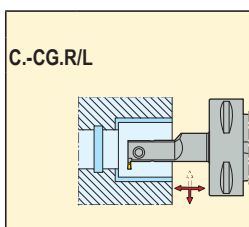
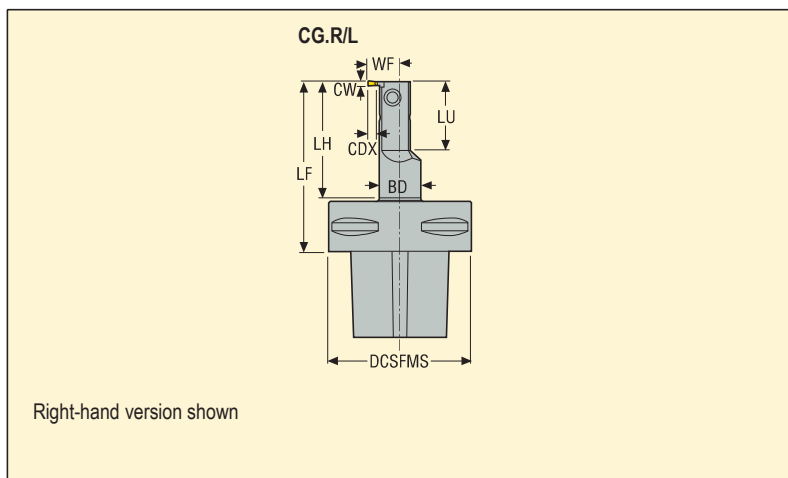

Capto size	CW	Designation	Dimensions in mm								KG	Seat size	LC..1902..
			BD	DCSFMS	WF	LF	LH	LU	CDX	DCINN*			
C4	2	C4-CGHR-15075-1902	18,0	40	14,5	75	53	30,5	5,5	20	0,4	2	LC..1902..
		C4-CGHL-15075-1902	18,0	40	14,5	75	53	30,5	5,5	20	0,4	2	LC..1902..
C5	2	C5-CGHR-15075-1902	18,0	50	14,5	75	53	30,5	5,5	20	0,5	2	LC..1902..
		C5-CGHL-15075-1902	18,0	50	14,5	75	53	30,5	5,5	20	0,5	2	LC..1902..
C6	2	C6-CGHR-15075-1902	18,0	60	14,5	75	51	30,5	5,5	20	0,9	2	LC..1902..
		C6-CGHL-15075-1902	18,0	60	14,5	75	51	30,5	5,5	20	0,9	2	LC..1902..
C4	2	C4-CGJR-19080-1902	23,0	40	19,0	80	58	30,5	7,5	25	0,4	2	LC..1902..
		C4-CGJL-19080-1902	23,0	40	19,0	80	58	30,5	7,5	25	0,4	2	LC..1902..
C5	2	C5-CGJR-19080-1902	23,0	50	19,0	80	58	30,5	7,5	25	0,6	2	LC..1902..
		C5-CGJL-19080-1902	23,0	50	19,0	80	58	30,5	7,5	25	0,6	2	LC..1902..
C6	2	C6-CGJR-19080-1902	23,0	60	19,0	80	56	30,5	7,5	25	0,9	2	LC..1902..
		C6-CGJL-19080-1902	23,0	60	19,0	80	56	30,5	7,5	25	0,9	2	LC..1902..

* DCINN – minimum bore diameter, see page(s) 527

Spare Parts, Parts included in delivery

For holder	Clamp key	Clamp screw	Torque value Nm
CG.R/L..-1902	T15P-7	L85011-T15P	5,0

Please check availability in current price and stock-list

Toolholders for inserts LCGA, LCGF, LCGN, LCMF and LCMR



• For inserts programme, see page(s) 628-631, 647

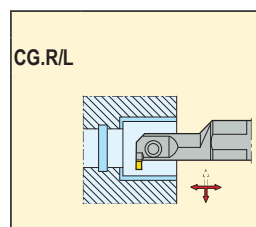
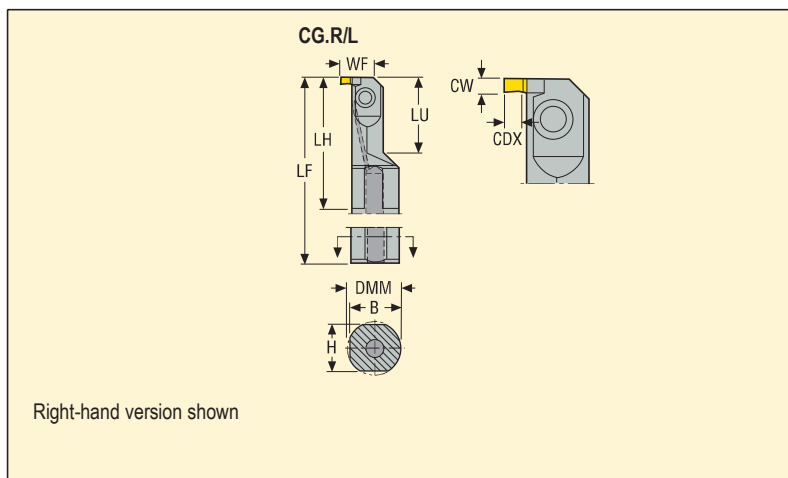

CG.R/L	CW	Designation	Dimensions in mm								KG	Seat size	Insert	
			DMM	H	B	LF	LH	LU	WF	CDX				DCINN*
3		A16Q-CGER1303	16	15	15,5	180	40	25	10,2	3,0	16	0,3	3	LC..1303..
		A16Q-CGEL1303	16	15	15,5	180	40	25	10,2	3,0	16	0,3	3	LC..1303..
3		A20R-CGFR1303	20	18	19,0	200	52	30	14,5	5,5	20	0,4	3	LC..1303..
		A20R-CGFL1303	20	18	19,0	200	52	30	14,5	5,5	20	0,4	3	LC..1303..
3		A25S-CGHR1303	25	23	24,0	250	64	40	19,0	7,5	25	0,8	3	LC..1303..
		A25S-CGHL1303	25	23	24,0	250	64	40	19,0	7,5	25	0,8	3	LC..1303..
3		A32T-CGJR1303	32	30	31,0	300	77	50	25,5	10,5	32	1,6	3	LC..1303..
		A32T-CGJL1303	32	30	31,0	300	77	50	25,5	10,5	32	1,6	3	LC..1303..
4		A20R-CGFR1304	20	18	19,0	200	52	30	14,5	5,5	20	0,4	4	LC..1304..
		A20R-CGFL1304	20	18	19,0	200	52	30	14,5	5,5	20	0,4	4	LC..1304..
4		A25S-CGFR1304	25	23	24,0	250	64	40	19,0	7,5	25	0,8	4	LC..1304..
		A25S-CGFL1304	25	23	24,0	250	64	40	19,0	7,5	25	0,8	4	LC..1304..
4		A32T-CGHR1304	32	30	31,0	300	77	50	25,5	10,5	32	1,6	4	LC..1304..
		A32T-CGHL1304	32	30	31,0	300	77	50	25,5	10,5	32	1,6	4	LC..1304..

* DCINN – minimum bore diameter, see page(s) 527

Spare Parts, Parts included in delivery

For holder	Clamp key	Clamp screw	Torque value Nm
A16Q-..	T15P-7	L85011-T15P	5,0
A20R-..	T15P-7	L85011-T15P	5,0
A25S-..	T15P-7	L85011-T15P	5,0
A32T-..	T15P-7	L85011-T15P	5,0

Accessories, to be ordered separately

For holder	Coolant adapter
A16Q-..	SEAL16
A20R-..	SEAL20
A25S-..	SEAL25
A32T-..	SEAL32

Please check availability in current price and stock-list

Toolholders for inserts LCGF, LCGN, LCMF and LCMR



• For inserts programme, see page(s) 633-646, 648-649

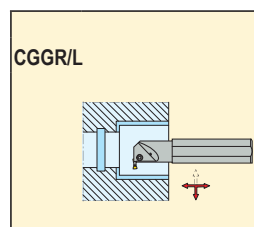
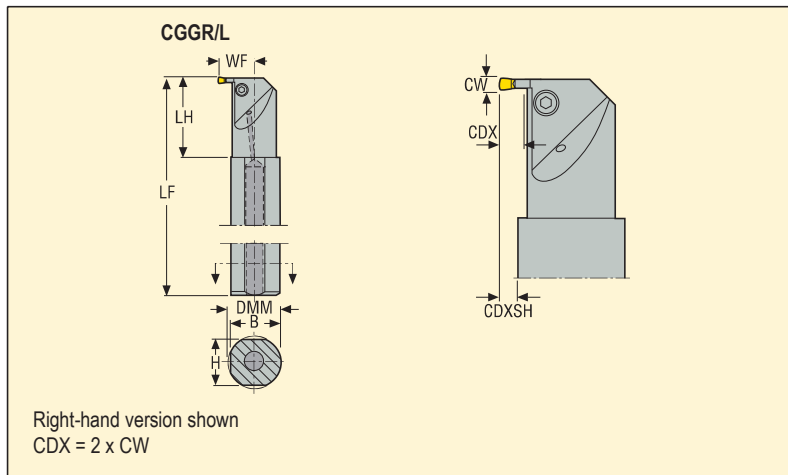

CGGR/L	CW	Designation	Dimensions in mm									KG	Seat size	Insert
			DMM	H	B	LF	LH	WF	CDX	CDXSH**	DCINN*			
3		A40T-CGGR03	40	37	38,5	300	60	26	6	5,5	45	2,5	3	LC..1603..
		A40T-CGGL03	40	37	38,5	300	60	26	6	5,5	45	2,5	3	LC..1603..
4		A40T-CGGR04	40	37	38,5	300	60	27	8	6,5	45	2,4	4	LC..1604..
		A40T-CGGL04	40	37	38,5	300	60	27	8	6,5	45	2,4	4	LC..1604..
5		A40T-CGGR05	40	37	38,5	300	60	28	10	7,5	45	2,4	5	LC..1605..
		A40T-CGGL05	40	37	38,5	300	60	28	10	7,5	45	2,4	5	LC..1605..
6		A40T-CGGR06	40	37	38,5	300	60	29	12	8,5	45	2,4	6	LC..1606..
		A40T-CGGL06	40	37	38,5	300	60	29	12	8,5	45	2,4	6	LC..1606..

* DCINN – minimum bore diameter, see page(s) 527

** If toolholder enters bore more than LH

Spare Parts, Parts included in delivery

Accessories, to be ordered separately

For holder	Clamp key	Clamp screw	Torque value Nm	For holder	Coolant adapter
-.03	3SMS795	MC6S4X14	3,5	-.03	SEAL40
-.04	4SMS795	MC6S5X14	5,0	-.04	SEAL40
-.05	4SMS795	MC6S5X14	5,0	-.05	SEAL40
-.06	5SMS795	TCEI0614	8,0	-.06	SEAL40

Please check availability in current price and stock-list

